

# KINX IR Book

For Investors and Stockholders

IR Team([ir@kinx.net](mailto:ir@kinx.net))

May 2026

**KINX**

## ※ Disclaimer

This material has been prepared to help you understand our company's current status and services. Some of the information, such as outlooks and investment points, is based on general data on relevant industry trends and our future plans. Therefore, please note that it may change depending on the market situation and business environment.

## I N D E X

---

### **I. Corporate Status**

### **II. Service Architecture**

1. IDC, CloudHub
2. IX
3. CDN, Cloud

### **III. Service Features and Competitiveness**

### **IV. Outlook and Investment Points**

**KINX(Korea Internet Neutral eXchange) is a company that provides total internet infrastructure services to Corporate customers (B2B).**

We provide IDC, Cloudhub, IX, CDN, and Cloud services based on data centers and network infrastructure.

In addition, we have been growing with stable service for more than 20 years, and more than 70% of corporate members are technology, development, and consulting experts.

Company Name	KINX, Inc. (Korea Internet Neutral eXchange)
Established Date	June 17, 2000
CEO	Jee Wook Kim
Main Services	IDC, CloudHub, IX, CDN, Cloud
Head Office	4F, Gabia @, 34, Gwacheon-daero 7na-gil, Gwacheon-si, Gyeonggi-do, KOREA
1 <sup>st</sup> Branch Office / Central IDC (Dogok) 2 <sup>nd</sup> Branch Office / New IDC(Gwacheon)	5F, Daelim Acrotel, 13, Eonju-ro 30-gil, Gangnam-gu, Seoul, KOREA Building B, Gabia @, 34, Gwacheon-daero 7na-gil, Gwacheon-si, Gyeonggi-do, KOREA
Scale	Revenue: 159.2 billion won(consolidated as of '25), Number of employees: 171
Official website	<a href="http://www.kinx.net">http://www.kinx.net</a>

# I. Corporate Status

## KINX has been growing steadily based on its network services and data center services.

As of the end of 2025, on a consolidated basis, the average annual growth rate of revenue over the past five years was 17.9%, and the average operating margin was 20.1%. Excluding subsidiaries, our separate revenue in 2025 was KRW 105.5 billion, up 11.8% from the previous year, and the operating margin was 19.2%. Revenue is steadily increasing due to increased network usage and

demand for CloudHub by domestic and foreign customers, and the operating margin remains in the 20% range. The increase in revenue that year was largely due to increased usage by existing customers, accounting for more than 70%. Attracting new customers appears to be contributing to the increase in revenue over time compared to the early days of the service.

Revenue(Growth rate)

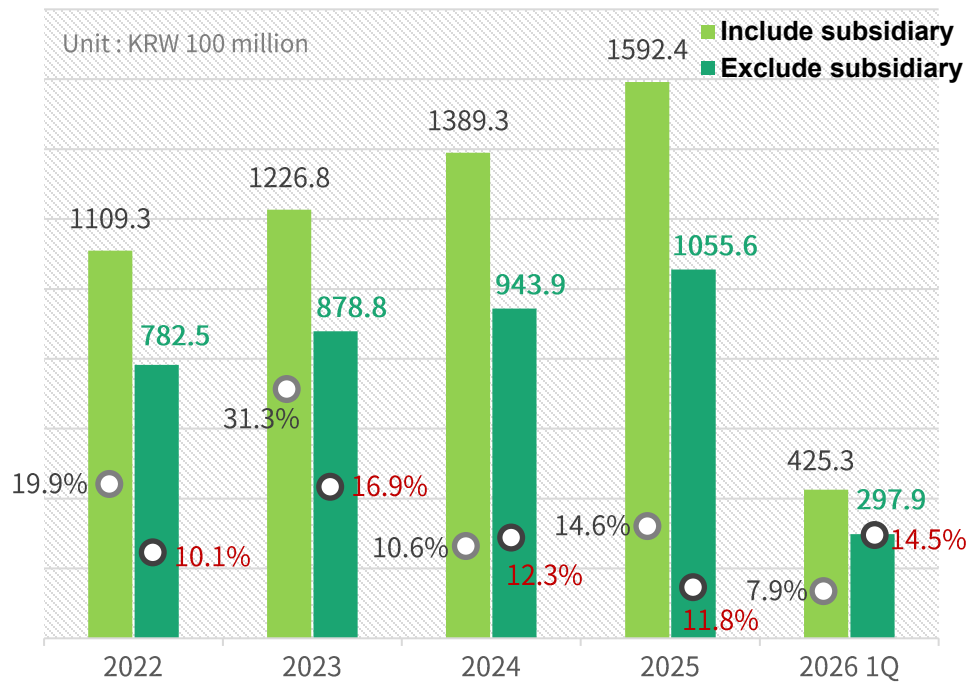

Operating Margin(Rate)

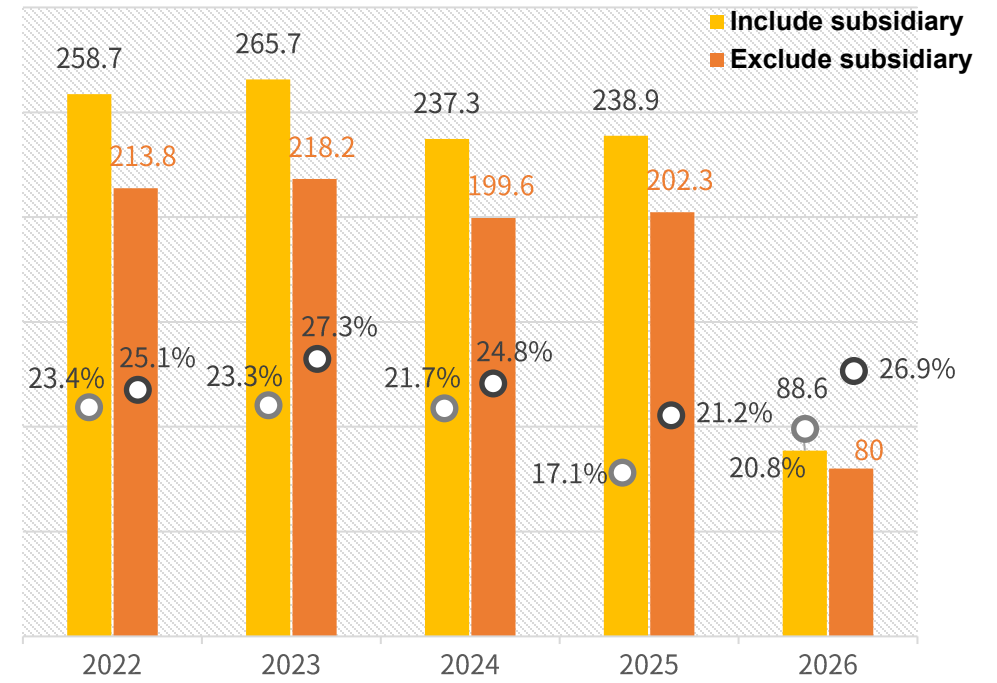

## Network infrastructure services provided by KINX can be divided into IDC, CloudHub, IX, CDN, and Cloud Services.

Currently, IDC and CloudHub services are driving our growth, with IDC services accounting for approximately 66% of total revenues, CloudHub accounting for about 13%, and IX services making up around 11%. The proportion of IDC service revenues is expected to increase significantly with our new data center(Gwacheon). Notably, CloudHub was originally part of IDC's network services, but from 2023, after surpassing IX service revenues, CloudHub was classified separately and have continued to grow alongside the expansion of the domestic cloud market.

Revenue proportions by service



[Data] revenue proportions by service  
(Based on separate income statement in 2025)

Service Category	Share of Revenues (100% in total) *approximately	Sales/Cost Factor
<b>IDC</b>	66.8%	Rack power consumption, Network(Traffic)
<b>CloudHub</b>	13.5%	Network(Traffic)
<b>IX</b>	11.3%	Network(Traffic) *Port charge
<b>CDN</b>	3.4%	Contents capacity(storage), Network(Traffic)
<b>Cloud</b>	1.4%	Resource usage(VM), Network(Traffic)

# I. Corporate Status

## Starting from the Dogok Center, KINX is advancing its efforts to expand and operate a network of interconnected data centers.

We currently operate a self-owned center in Dogok and lease IDCs from providers such as LG CNS, Samsung SDS, and Hostway in the Gasan, Sangam, and Bundang areas. Through this infrastructure, we offer customized, neutral infrastructure services tailored to our customers.

Additionally, we have established global network points of presence (PoPs) in Japan and Hong Kong.

Furthermore, we had finished construction\* which is new self-owned data center in Gwacheon for our infrastructure expansion.

\* Construction approval granted on August 21, 2024, followed by service commencement in December 2024.

### KINX Data Center Location

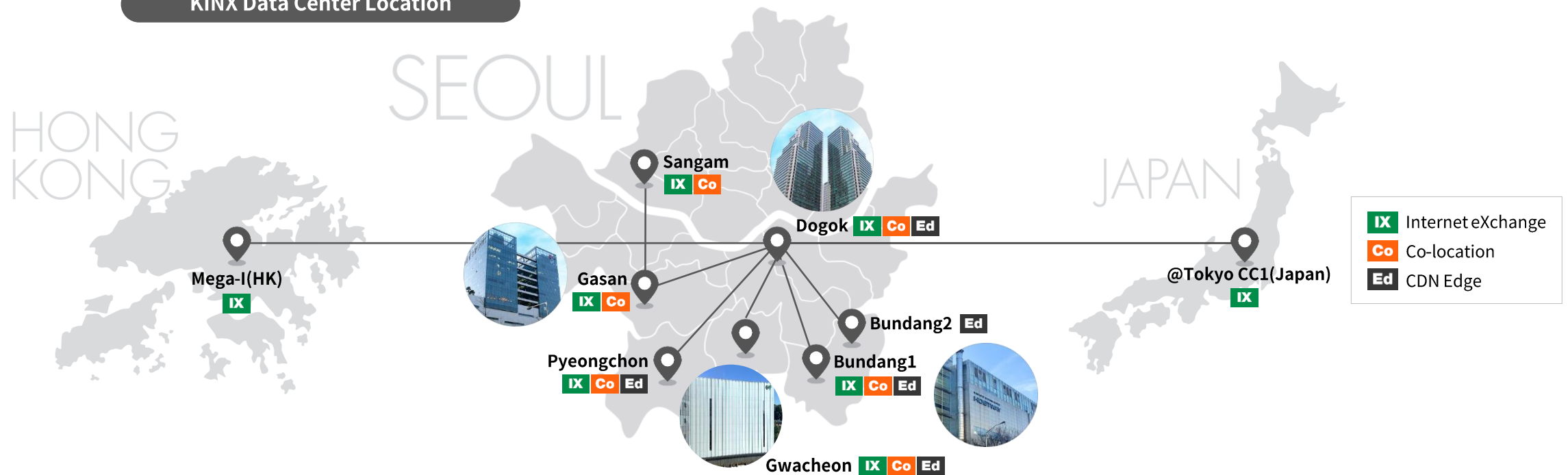

※ Details regarding the investment and scale of the new data center in Gwacheon will be provided on the last page.

## II. Service Architecture

**Before explaining our service structure, we would like to briefly introduce some terms that are frequently used in the description to aid understanding.**

Types of Customers	CP (Contents Provider)	A company that produces or owns Internet content (broadcasting, movies, games, sound recordings, media, applications, etc.) and provides content to Internet users through the Internet. General businesses that extensively store and utilize content on servers are also within the scope of Content Providers (CP).
	CSP (Cloud Service Provider)	The entity that provides cloud services to individuals or companies. Those who use the cloud service a lot are generally CPs.
	ISP (Internet Service Provider)	The entity that provides Internet access services to individuals and companies. Internet users can access the Internet through their ISP. Our ISP customers mainly consist of MSO(Multiple System Operators).
Infrastructure Terminology	Rack	This refers to rack-mounted standardized shelves for installing servers, storage, internet communication equipment, etc. One standard rack can accommodate up to 42 servers, but due to heat and other reasons, around 20 devices are typically installed.
	Rack space	This refers to the space where racks are placed. It's also used to describe the scale of a data center in terms of its rack capacity. The term indicates how much space is available for placing racks, which determines how many racks can be accommodated.
	bandwidth	This is a concept related to the capacity (amount of traffic) of a network line. It refers to the maximum range or width through which communication traffic can flow at once. For instance, a 1Gbps bandwidth means the circuit can accommodate up to 1GB of internet traffic per second.
	Transit	It's commonly referred to as 'transit.' Transit in telecommunications refers to connecting between sender and receiver through one or more exchange points. The data center of KINX has lines from various line operators, so customers can connect to the desired line operator through KINX.

### IDC services are based on physical infrastructure, such as data centers and large-scale internet network circuits.

A data center is a specialized facility that provides an optimal environment for operating computer equipment like servers, storage, and network devices. Often likened to a "server hotel," a data center can be considered a dedicated building for large-scale computer rooms. Additionally, data centers are interconnected with large-scale network circuits, offering various connectivity services.

#### Infrastructure

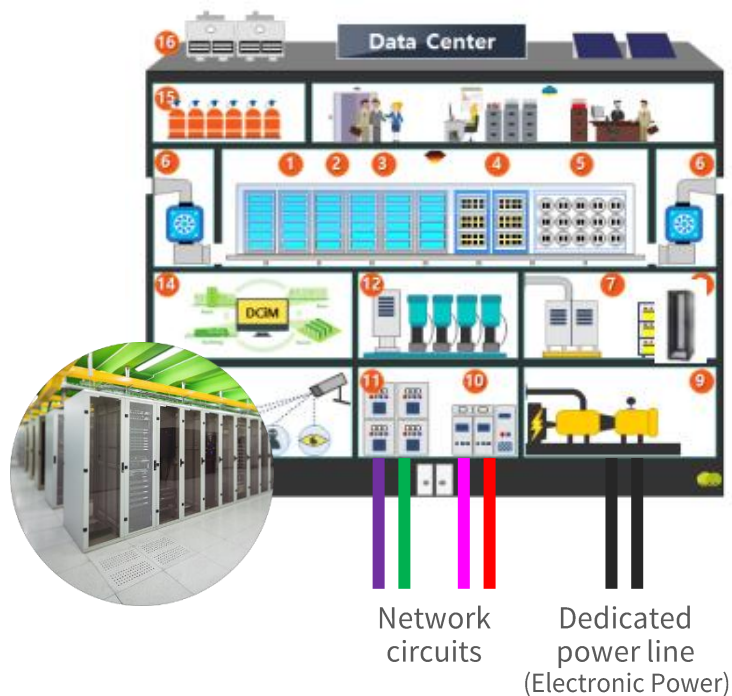

#### Service



Sales

Marketing  
(online/offline)

Technical  
Consulting

Infrastructure  
Purchase/Procurement



Operations (System/Network/Infrastructure)

Notice No. 2016-72 from the Ministry of Science, ICT and Future Planning, 'Guidelines on Essential Facilities and Scale for Private Data Center Construction and Operation to Promote Data Center Development.

- Article 3 (Scale): The scale of a data center requires a computing room floor area within the building of at least 500 sqm (approximately 151 pyeong).

### The billing structure of IDC services can be divided into two main components.

Firstly, customers are charged based on **①space usage fees**, which depend on the number of racks they use and the required power consumption per rack. Secondly, **②network circuit usage fees** are assessed based on the volume of network traffic generated by the customer's equipment and their desired domestic and international connectivity services. This structure allows customers to be billed monthly based on their data center space usage and the volume of network traffic they generate.

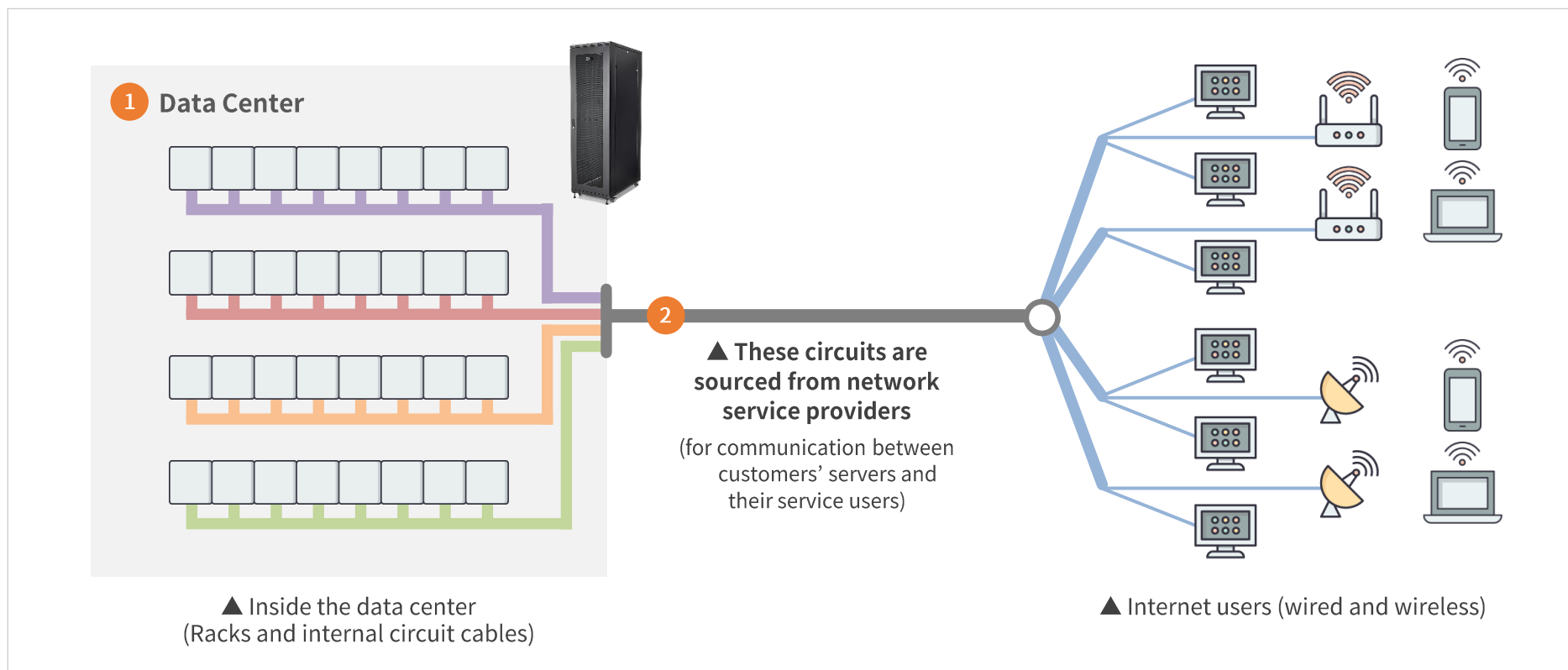

## II. Service Architecture

### IDC offers a variety of network services.

These include the fundamental service of Local IP Transit, enabling communication between internal customer computing resources and internet users. Additionally, IDC provides various network services such as International IP Transit for overseas connections, Data Center Interconnect(DCI) and Cross Connect for those who need dedicated interconnection within our data centers.

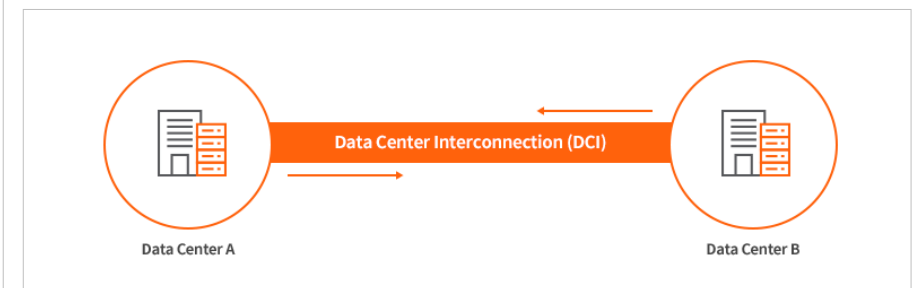
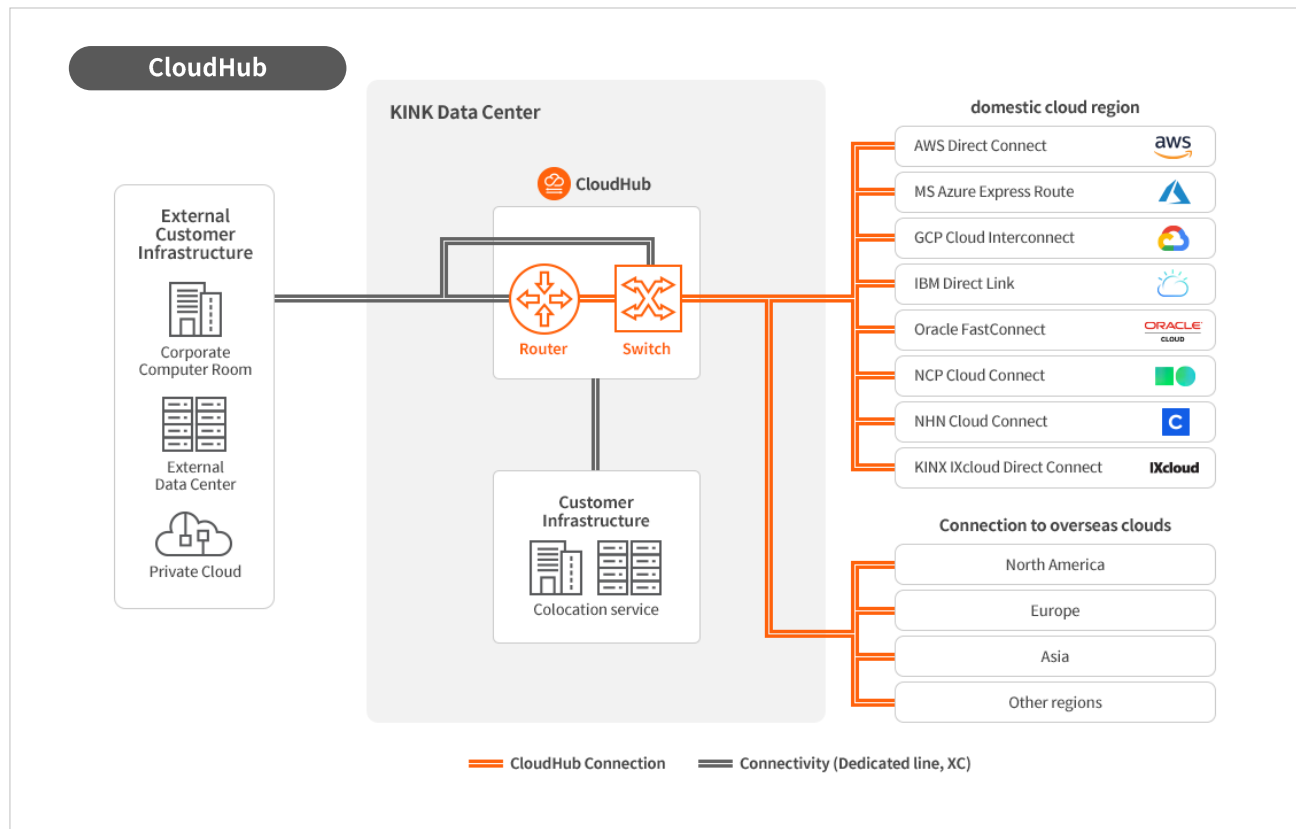

### KINX's CloudHub service provides direct connectivity to the largest number of CSPs in South Korea.

CloudHub enables enterprises looking to utilize multi-cloud and hybrid cloud environments to reduce network costs and achieve fast cloud access speeds. The demand for CloudHub continues to grow with increasing numbers of circuit connections, driven by rising domestic demand in digital transformation and increasing demand for multi-cloud solutions, as well as the activation of AI services based on cloud platforms. This demand is expected to continue growing in the future.

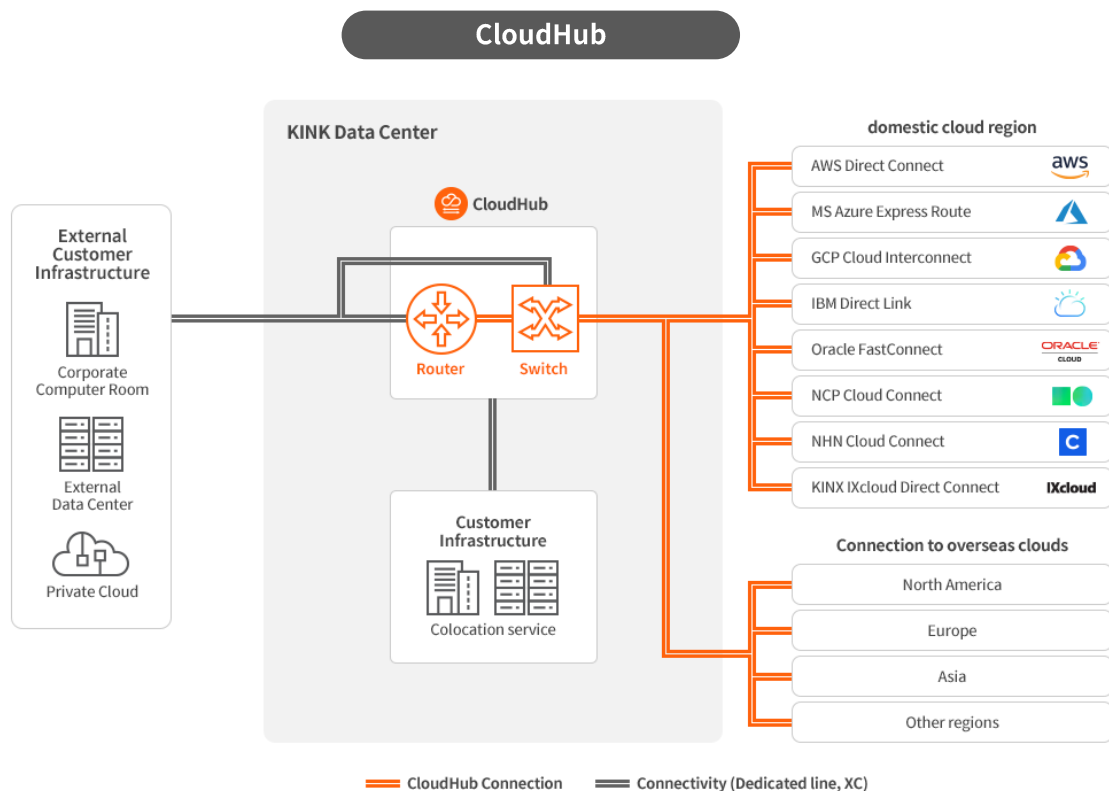

Enterprise Cloud Strategy  
1000+ employees

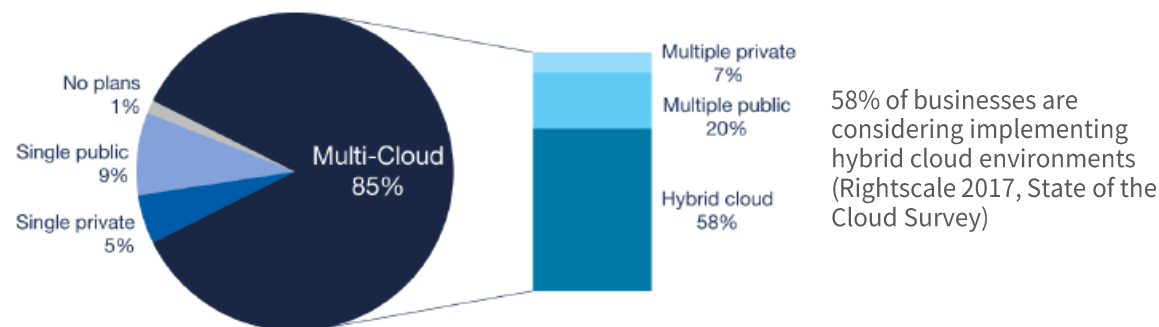

#### Multi-Cloud

Multi-cloud is a phenomenon emerging recently in leading cloud-centric countries like the United States, led by major cloud providers known as the 'Big 4' (AWS, Microsoft, IBM, Google). In Korea, 69% of IT companies prioritize considering cloud for IT infrastructure setup and management, with 81% of them planning to adopt multiple cloud providers. By utilizing two or more clouds, companies can distribute dependencies and leverage the strengths of each service. Therefore, the importance of cloud interconnection platforms (Cloud eXchange) that provide integrated operational management environments for these heterogeneous clouds is expected to grow significantly.

## II. Service Architecture

**IX(Internet Exchange) is a platform that allows efficient interconnection between ISPs with their own network infrastructures and between different ISP networks.**

KINX operates a platform, equipped with communication equipment called 'switches,' where ISPs can connect their network circuits to these switches. Once ISPs are connected to this platform, the members of IX platform are able to efficiently and economically exchange internet traffic each other.

**Direct peer-to-peer connections between all ISPs : High Cost, Inefficient**

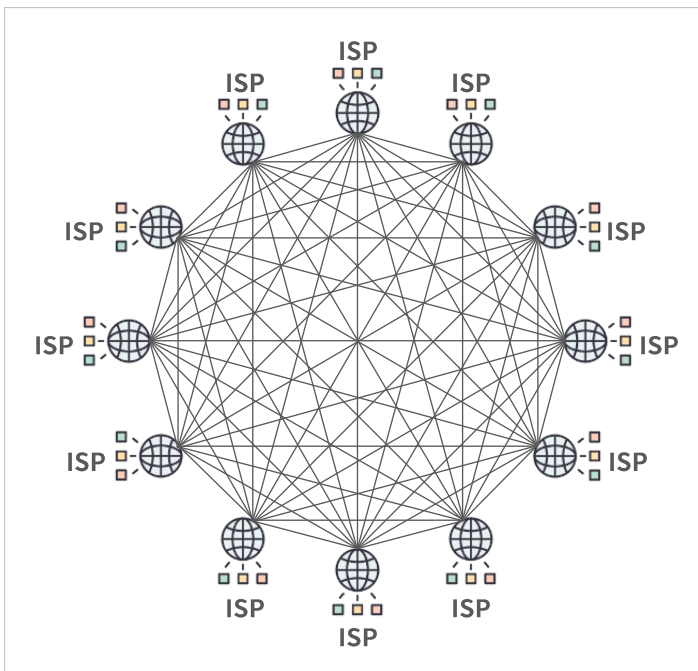

**Interconnection between ISPs via IX : Low Cost, High Efficiency**

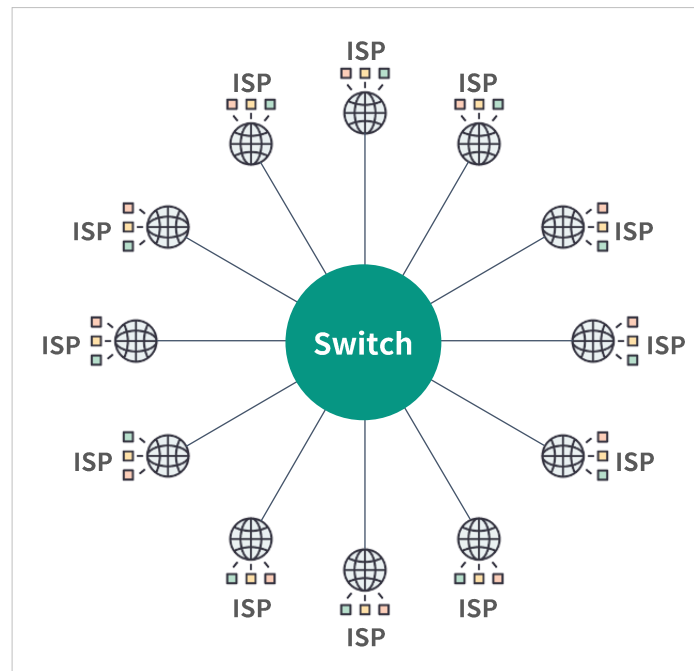

**ISP(Internet Service Provider)** refers to a provider that operates its own network infrastructure and offers internet connections to internet users.



▲ IX Switch

### Our major ISP customers are cable TV operators (Multiple System Operator, MSO).

Given the nature of IX services, where revenue is generated through traffic interconnection, the number of internet subscribers connected to the interconnection network, a critical variable in the flow of internet traffic, can be used to estimate the approximate scale of interconnection. KINX's main IX customers, MSO, have approximately 2.17 million high-speed internet subscribers, which accounts for 10.0% of the total high-speed internet subscribers including corporate subscribers. It can be estimated that the internet traffic that 10% of all the internet users is using in the country is going through KINX IX.

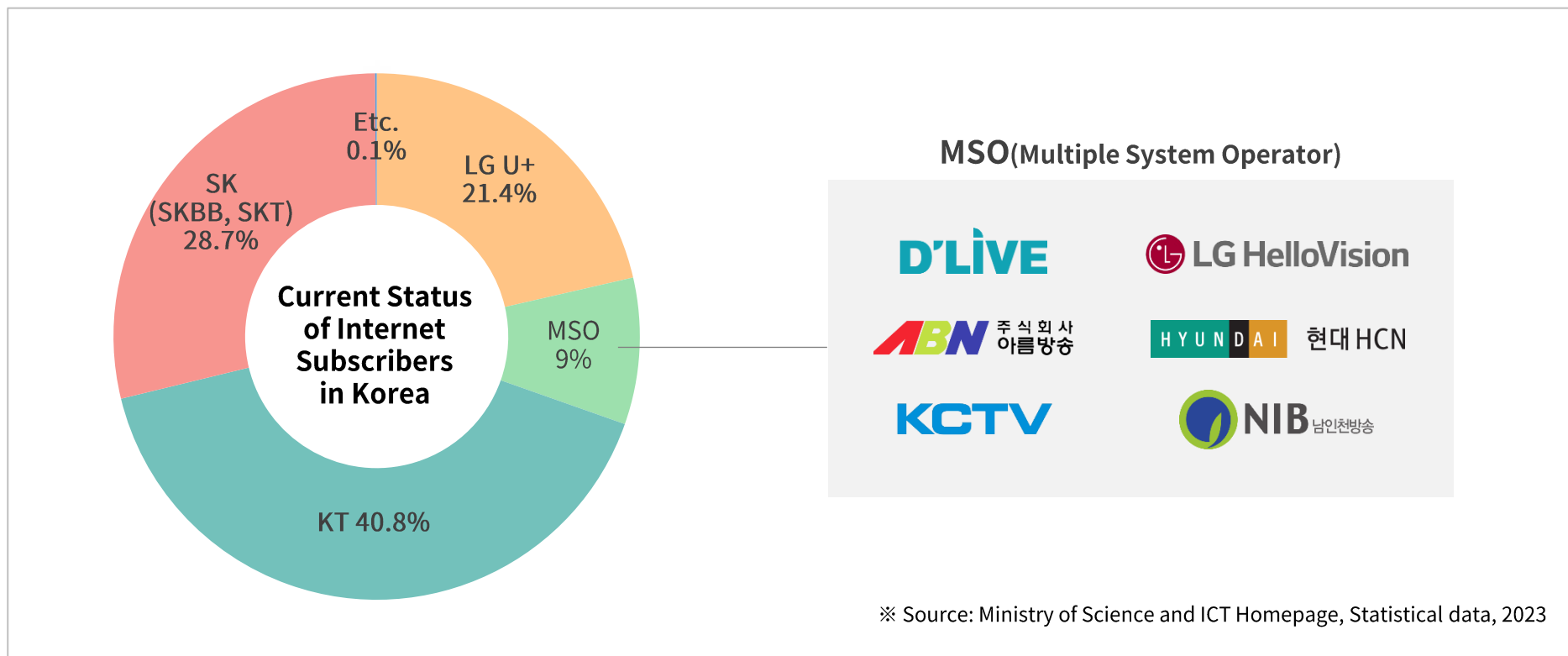

## II. Service Architecture

**The fees for IX services are determined based on both the bandwidth and the number of circuit ports that customers connect to the IX switch.**

Bandwidth tiers for IX switches include categories such as 1Gbps, 10Gbps, and 100Gbps, with fees assigned accordingly. The total fee is calculated based on the selected bandwidth tier and the number of circuit ports. Therefore, traffic fluctuations within the allotted bandwidth do not affect the fee. However, if traffic exceeds the specified bandwidth, additional port connections will be necessary, leading to extra charges.

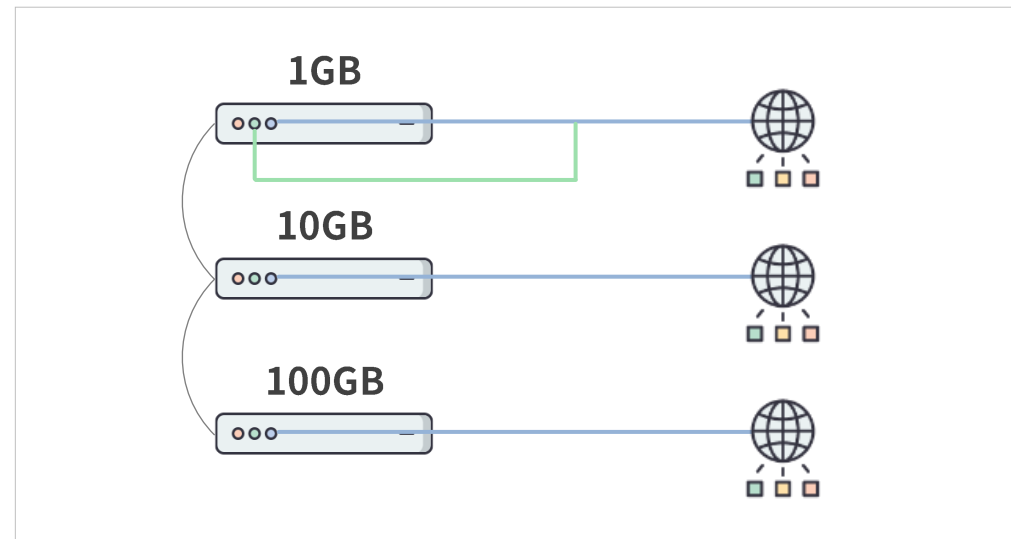
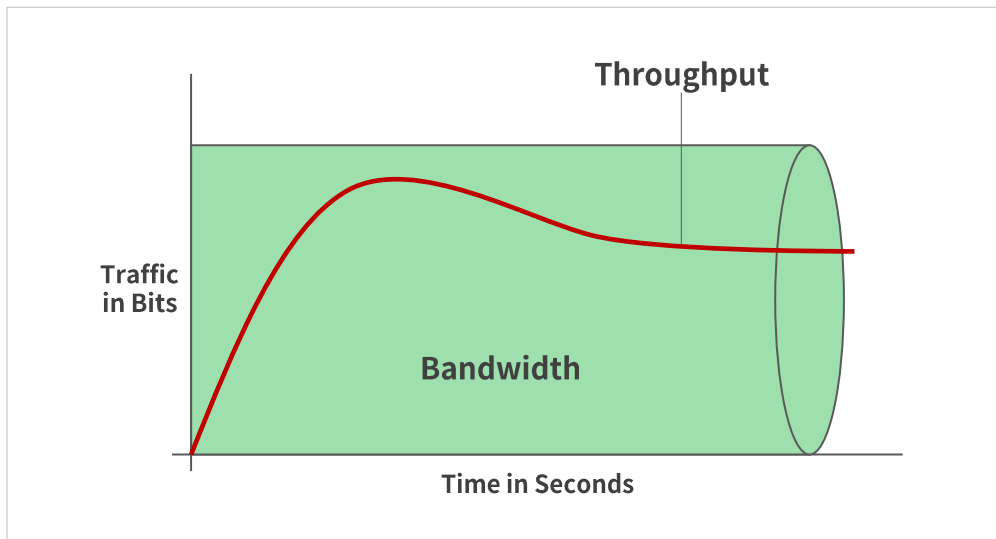

**Bandwidth** refers to the maximum capacity or width through which communication traffic can flow at once. For example, if a connection has a bandwidth of 1Gbps, it means that up to 1 GB per second of internet traffic can flow through the channel simultaneously.

IX Switch ▶



## II. Service Architecture

**KINX IX customers primarily include ISPs that operate internet user networks, as well as CP and CSP customers who wish to deliver content to internet users.**

The ISPs consist of MSOs like D'Live, Hyundai HCN, LG HelloVision, and ABN, along with domestic and international network operators. CPs include companies like Naver, Kakao, and Dropbox, while CSPs include Amazon, MS, Oracle, Google, IBM, Alibaba, and Tencent.

[www.peeringdb.com](http://www.peeringdb.com)

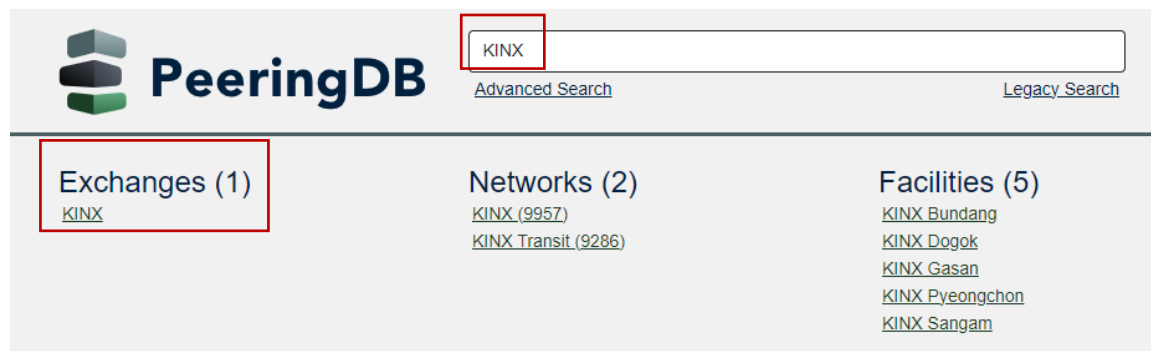

The screenshot shows the PeeringDB website interface. At the top left is the PeeringDB logo. To its right is a search bar containing the text "KINX". Below the search bar are two links: "Advanced Search" and "Legacy Search". Below the search bar, the results are categorized into three columns: "Exchanges (1)" with a link to "KINX", "Networks (2)" with links to "KINX (9957)" and "KINX Transit (9286)", and "Facilities (5)" with links to "KINX Bundang", "KINX Dogok", "KINX Gasan", "KINX Pyeongchon", and "KINX Sangam".

### Domestic ISP sectors (MSO/SO)



### Other domestic ISP sectors



### Domestic and international CP/CSP sectors



## II. Service Architecture

### CDN service distributes internet content to users efficiently.

It's a service that prevents access failures or delays even when there's a high volume of simultaneous accesses from internet users to customer's servers. Services include downloads, streaming, and more. Fees are typically depending on the amount of traffic generated by the content being delivered.

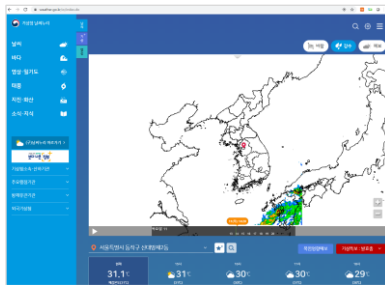
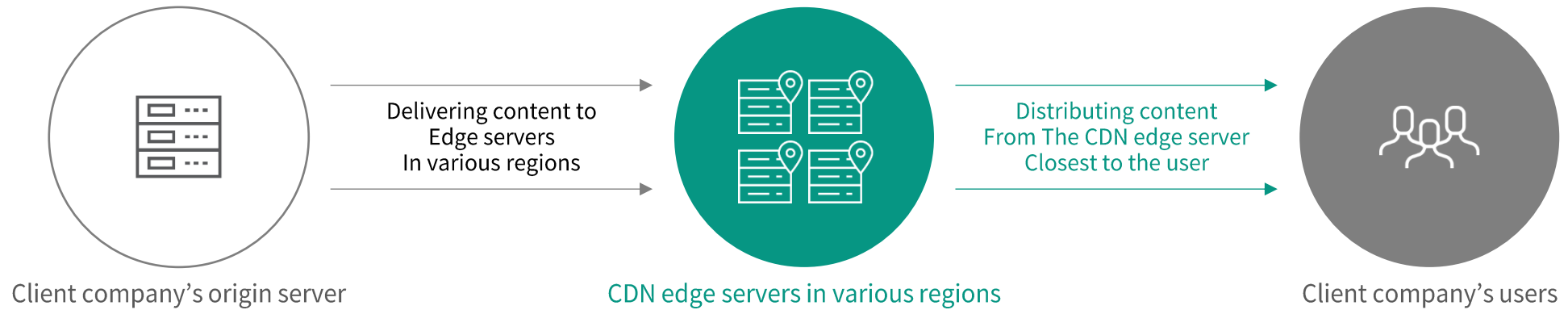

▲ Korea Meteorological Administration's website



▲ National Tax Service's year-end tax settlement page

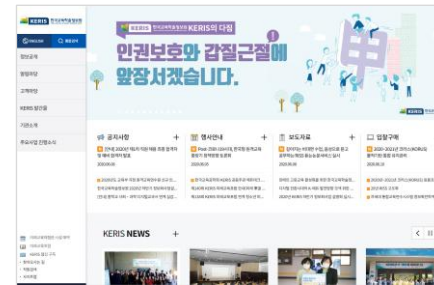

▲ Korea Education and Research Information Service(KERIS) (Digital Textbook distribution)

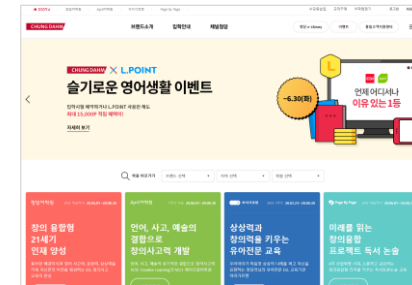

▲ Creverse (Chungdahm) (language education)

### Cloud services are also referred to as virtual server services.

Customers can install and operate software over the internet through cloud service portal without owning physical servers, storage, or other computing equipment. Customers pay fees based on the quantity of cloud virtual servers (VMs) created and the amount of traffic between virtual servers and internet users.

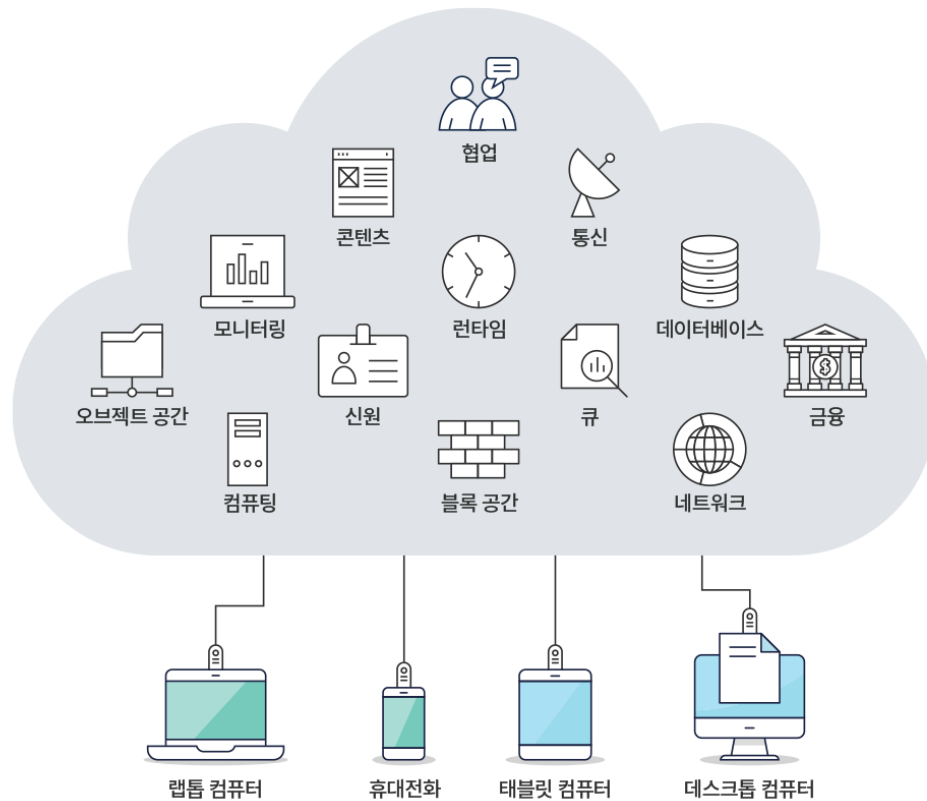

### What is IXcloud?

IXcloud is a public cloud platform where KINX has been in commercial service since September 2012. It is based on OpenStack, an open-source cloud computing platform that allows easy deployment and scalable expansion regardless of scale. OpenStack, utilized by over 180 companies worldwide, provides an environment similar to that of large-scale commercial cloud services like AWS (Amazon).

Leveraging KINX's extensive network, data center infrastructure, and operational expertise, IXcloud offers stable and reliable cloud services.



## KINX's greatest strength and competitive edge lie in its high-quality customized services tailored to customer needs.

KINX offers various options for data center environments and network connectivity services, allowing customers to implement their own policies and preferences. This customer-centric approach is referred to as 'neutral' service. Customers can freely deploy their data center and circuit operation policies, receive fast and high-quality services, and benefit from cost savings and other economic advantages. KINX constantly endeavors to swiftly provide customers with a wide range of service options they require, while staying attuned to changes in customer needs and the market.

### Neutral Data Center

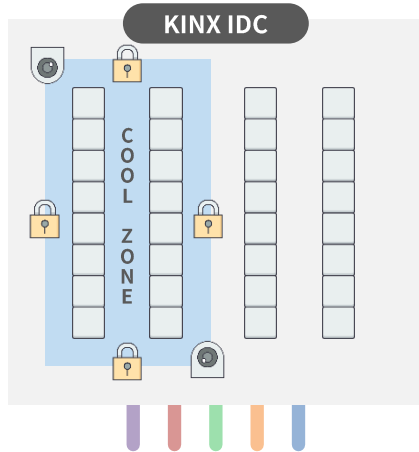

1. Various rack environments can be configured according to customer's needs or policies.
2. Leading in the network line(circuit) of various line providers
  - Ensure customer's line(circuit) selection and line cost reduction
  - Line duplication
3. Directly managed and operated by our technical staff

→ Tailored to customer's policy

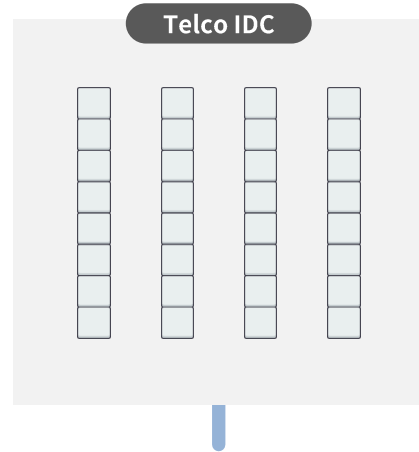

1. Configure rack environment according to Telco's IDC policy
2. Only leading in the network line of corresponding Telco
3. In general, IDC management personnel are outsourced because of standardized

→ Tailored to Telco's policy

### Neutral IX The only one in Korea

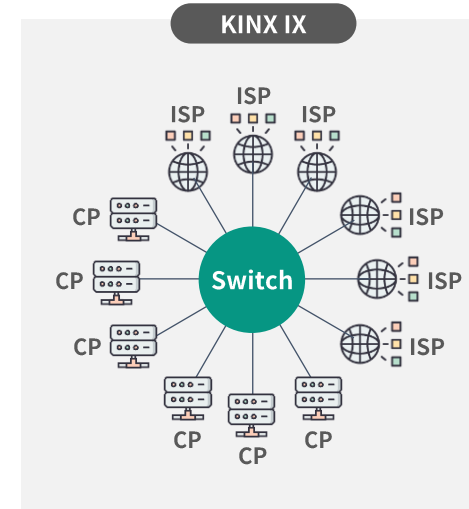

#### Direct interworking via IXP (Peering)

1. Operator has permission to choose.
2. Low cost (Only Port Fee)
3. Short Routing path

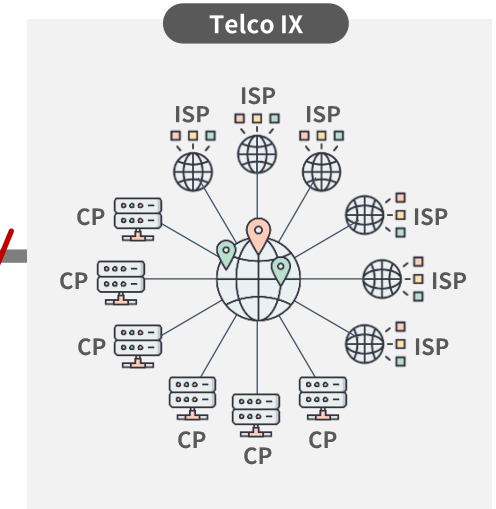

#### Interworking via ISP (lines)

1. Operator has no choice. Namely, depends on IXP.
2. High cost (Port Fee + Traffic Fee)
3. Long Routing path

#### KINX offers diverse network options to its customers.

Customers can selectively connect with various domestic and international internet service providers, ensuring network operational stability and cost-effectiveness. Compared to other providers primarily offering data center space, KINX maintains a relatively higher proportion of network services, contributing to a high operating profit margin in the 20% range. With our strong network technology and expertise, KINX is committed to expanding domestic and international networks to meet customer demands effectively in the future.

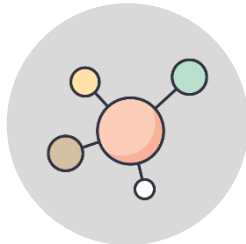

**IX**  
(Internet Exchange,  
Peering)



**Global PoP**  
(Point of Presence)



**Transit**  
(Select/connect various domestic  
and foreign network operators)

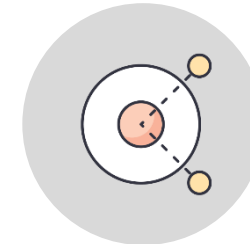

**Cross Connect**  
(Connect two points within  
the same data center)



**DCI**  
(Data Center Interconnection)

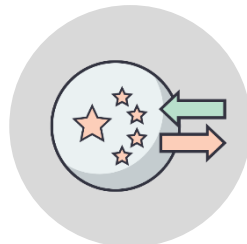

**CDC**  
(China Direct Connect)



**Cloudhub**  
(Cloudhub, Domestic/International)

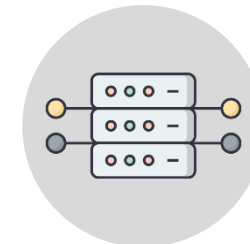

**Dedicated line**  
(dedicated circuit)

### III. Service Features and Competitiveness

With over 20 years of service expertise and technical competence, KINX provides stable services to various industries both domestically and internationally, including corporate and government entities.

The customer references secured by KINX instill trust and confidence not only among existing customers but also prospective clients, significantly enhancing customer retention and competitive edge in the market.

kakao

amazon

Google

NAVER



D'LIVE

Microsoft

Disney+

Connect Wave

SAMSUNG  
삼성SDS

ORACLE®

Alibaba.com™

NBP  
NAVER  
BUSINESS  
PLATFORM

Accelerating Your World  
CDNetworks

KERIS  
한국교육학술정보원

자본시장 IT 파트너  
koscom  
www.koscom.co.kr

ncia  
정부통합전산센터  
National Computing & Information Agency

기상청

NC

HYUNDAI

## IV. Outlook and Investment Points

### Recently, the cloud industry has been a key driver that directly increases the demand for domestic data centers in South Korea.

Starting from 2018, both international cloud providers like Amazon and local cloud service providers have been actively stimulating the domestic cloud market. As domestic demand for cloud services continues to grow and the market expands, it is expected that the demand for data centers will steadily increase, driven by cloud service providers and enterprises seeking to use cloud services.

CSP  
Cloud Service Provider



#### Outlook for the domestic cloud market in South Korea

The growth momentum is definite. Not only in scale but also in conversion rates.

	Cloud Market					Estimate by Cloud Market Scenario					
	'14	'15	'16	'17		'18E	'19E	'20E	'21E	'22E	'17~'22 CAGR
Market size	524	766	1,189	1,513	Market size	1,998	2,421	2,724	3,027	3,330	
Cloud Utilization rate				5%	Cloud Utilization rate	7%	8%	9%	10%	11%	17.1%
YoY Growth		46.3%	55.2%	27.3%	YoY Growth	32.0%	21.2%	12.5%	11.1%	10.0%	
Market size	524	766	1,189	1,513	Market size	1,998	3,027	3,935	4,843	5,751	
Cloud Utilization rate				5%	Cloud Utilization rate	7%	10%	13%	16%	19%	30.6%
YoY Growth		46.3%	55.2%	27.3%	YoY Growth	32.0%	51.5%	30.0%	23.1%	18.8%	
Market size	524	766	1,189	1,513	Market size	1,998	3,330	4,540	5,751	6,962	
Cloud Utilization rate				5%	Cloud Utilization rate	7%	11%	15%	19%	23%	35.7%
YoY Growth		46.3%	55.2%	27.3%	YoY Growth	32.0%	66.7%	36.4%	26.7%	21.1%	

자료: 정보통신산업진흥원, 한국클라우드산업협회, 교보증권 리서치센터

#### AWS Accelerates AI & Cloud Innovation in Korea's Public and Medical Sectors

Amazon Web Services (AWS) is accelerating innovation in artificial intelligence (AI) and cloud computing across Korea's public and medical sectors. This trend is driven by the government's increasing focus on data sovereignty, strengthened governance, and the broader adoption of generative AI.

On the 21st, it was announced that AWS cloud services will be used to operate the AI chatbot system recently introduced by the Ministry of the Interior and Safety, which applies AI technology to approximately 120 administrative systems across government agencies. The government's plan to expand the use of AI chatbots in the public sector is also seen as part of this initiative.

According to AWS headquarters, "We are expanding our customized AI and cloud services for the public sector," emphasizing their continued investment and support for Korea's digital transformation.

### The internet-based industries in which our existing domestic, international, and potential customers operate are steadily growing and are expected to expand further in the future.

Additionally, the widespread adoption and establishment of cloud services by enterprises, the growth of the AI industry, and government policies promoting the IT sector are anticipated to accelerate this growth and expansion. KINX is expected to continue its steady growth by providing essential data center and network connectivity services to internet-based service providers and demand-driven companies.

#### [Focus] Korean Data Center Market

##### Expected to Grow 83% by 2030

The Korean data center market is projected to expand by **83% by 2030**, reaching a total power capacity of **2.64GW**, driven largely by strong investment in **AI and cloud infrastructure**. According to a report by market research firm **Mordor Intelligence**, the Korean colocation market is expected to grow at a **compound annual growth rate (CAGR) of 12.9%**, reaching **KRW 4 trillion (USD 3 billion)** by 2030.

##### AI and Cloud Demand Continues to Drive High Growth

AI-클라우드 수요 폭증으로 고성장 지속

Industry experts predict that Korea's data center power capacity—currently **1.44GW in 2024**—will nearly double to **2.64GW by 2030**, supported by AI- and cloud-related demand. As a result, the market size, valued at approximately **KRW 2.3 trillion (USD 1.7 billion)** in 2024, is expected to reach around **KRW 4.2 trillion (USD 3 billion)** by 2030.

In particular, AI data centers are emerging as a key driver, requiring significantly higher electricity consumption per unit area than general-purpose centers. According to industry sources, **AI and cloud service expansion** will continue to fuel steady infrastructure investment across both hyperscale and enterprise segments.

Meanwhile, the number of domestic data centers has continued to rise. As of the end of 2023, **Korea had 196 centers**, up from 182 in 2021—an increase of **about 13.1%**. The total power supply also grew from **1.01GW in 2020 to 1.44GW in 2024**, reflecting the sustained expansion trend.

##### Government Policy and Hyperscale Demand Driving Market Growth

The rapid advancement of AI technology among major corporations is accelerating growth in Korea's data center market. Global cloud service providers such as Amazon Web Services (AWS), Microsoft Azure, and Google Cloud Platform (GCP) are expanding their local infrastructure to meet rising demand.

According to industry sources, as companies increasingly rely on AI, cloud, and digital services, demand for large-scale (hyperscale) data centers continues to surge. Korea's government policies supporting digital transformation—such as the “Digital Platform Government” initiative—are also contributing to this expansion. Moreover, as the adoption of AI, 5G, and IoT increases, data usage and storage needs are rising sharply.

In 2024, the total IT load capacity of data centers nationwide is estimated at 1.44GW, up 42.6% from 2020 (1.01GW). By 2030, this figure is projected to reach 2.64GW, nearly double the current level, reflecting sustained growth momentum driven by both corporate investment and policy support.

##### Concentration in the Seoul Metropolitan Area and Expansion of Global Investment

글로벌 인공지능(AI) 데이터센터 시장 규모가 향후 7년간 연평균 26.8%씩 성장해 936억달러(약 131조원)에 달할 것으로 전망된다. 한국 데이터센터 시장은 서울 수도권 지역에 집중되어 있다. 서울 수도권 지역은 현재 전체 데이터센터 용량의 90% 이상을 차지하고 있다. 서울 수도권 지역의 데이터센터 용량은 2024년 기준 1.44GW에 달하며, 2030년에는 2.64GW로 증가할 것으로 예상된다. 서울 수도권 지역의 데이터센터 용량 증가는 AI, 클라우드, 디지털 서비스 수요 증가에 따른 것으로 보인다. 서울 수도권 지역의 데이터센터 용량 증가는 AI, 클라우드, 디지털 서비스 수요 증가에 따른 것으로 보인다.

As data traffic and storage needs soar, major global players—including AWS, Microsoft, Google, and Oracle—are actively investing in new sites. At the same time, domestic telecom and data center operators such as KT, SK Broadband, LG U+, Kakao, and Naver are also expanding capacity through new developments and joint ventures.

### We are expecting that our new IDC(Gwacheon) will be one of the major growth engine for KINX

Through this new IDC, we will provide customers with not only large-scale resource operation space but also state-of-the-art infrastructure and enhanced customer-tailored (neutral) services. This Gwacheon IDC is expected to attract strategic customers with its high-spec data center infrastructure and high network integration density, and we are actively engaging in sales activities. The establishment of this IDC will be an opportunity for KINX to achieve significant growth and further solidify our position as a neutral data center service provider.



▲ Perspective View of the Gwacheon New Office Building and Data Center(In the Gwacheon Knowledge Information Town)

#### Estimated Reference Information (for Gwacheon Data Center)

##### 1. Total Investment: Approximately KRW 180 billion

- This is the total budget for the building and facilities related to the data center.
- The total investment can be covered by our own cash reserves, profits/cash flow during the construction period, and low-interest industrial facility loans.  
→ As of the end of 2024, the borrowings are approximately 71.5 billion won. (repaying sequentially)

##### 2. Construction and Operation Scale

- Power capacity : 20MW and 10MW of that will be available to customers.(IT Load)  
And additional 20MW for backup.(It can be used only in emergency situations.)  
→ approximately 2.5 times compare to our whole current IDC's power usage
- Target PUE : 1.3 (currently 1.5 to 1.6) / Gwacheon IDC is certified as a 'Green data center'

##### 3. Operation/Revenue Goals

- We had started our service in Gwacheon IDC on Dec. 2024.  
→ Now, We are aiming for 80%\* customer contract by the end of 2025.  
\* '80%' means Full-Capacity for IDC
- Depreciation expenses are expected to be around KRW 7 billion annually  
→ Some depreciation costs have been incurred since last September, and the full amount has been reflected since December.

The new IDC is an additional facility that will be built while maintaining the existing IDCs. This IDC will be separate from the office building being constructed on the same site. KINX fully invests in constructs, and operates the IDC.



▲ Actual View of the Gwacheon Data Center

## Gwacheon IDC's current situation

### 1. Floor Structure

IT Load : 10Mw (Reached 100% contracted capacity)		
4F	A large number of medium or small customers	3Mw
3F	One large-scale customer	3Mw
2F	One large-scale customer	3Mw
1F	Gabia and some small clients	1Mw

### 2. Contract and Sales status\*

- 1) Contract : **10MW Fully Contracted** (Above Initial Target)  
→ Full Occupancy Expected by 1H 2028
- 2) Sales : Sales are expected to occur gradually starting in 2Q of 2025.  
→ Gradual growth starting from the lowest operating profit ratio of 15% (1Q of 2025)



▲ Actual View of the Gwacheon Data Center

### ※ Why is there a time gap between the contract date and the customer move-in date? (Timing of revenue recognition)

#### → Contract Date

: The point at which KINX and the customer have formally executed the contract. At this stage, no recurring revenue is generated (only potential one-time construction-related revenue may occur).

#### → Move-in

: After the contract is finalized, the customer begins equipment installation and ramp-up according to its internal schedule (typically around 2–3 months). During this period, no revenue is recognized as it is considered the customer's basic setup and testing phase.

- After the ramp-up period ends, actual revenue from space usage fees and network line charges begins to accrue.

- Depending on the customer, move-in may occur all at once; however, in the case of large-scale customers, equipment installation may be carried out in stages (monthly, quarterly, or semiannually).

# Thank you

“Expand Your Connection”

**KINX**